

INFINI**GLIDE**

EXPAND  
YOUR  
HORIZONS

 Quantum Windows

Quantum Windows  
11 Causeway Road  
Corby  
NN17 4DU

01536 260300

[quotes@quantumwindows.co.uk](mailto:quotes@quantumwindows.co.uk)

InfiniGLIDE 3 0721V2

Expand your horizons with the ultra slim sliding door with a 20mm sightline and stunning finish that offers a seamless transition alongside high performance.

 Quantum Windows

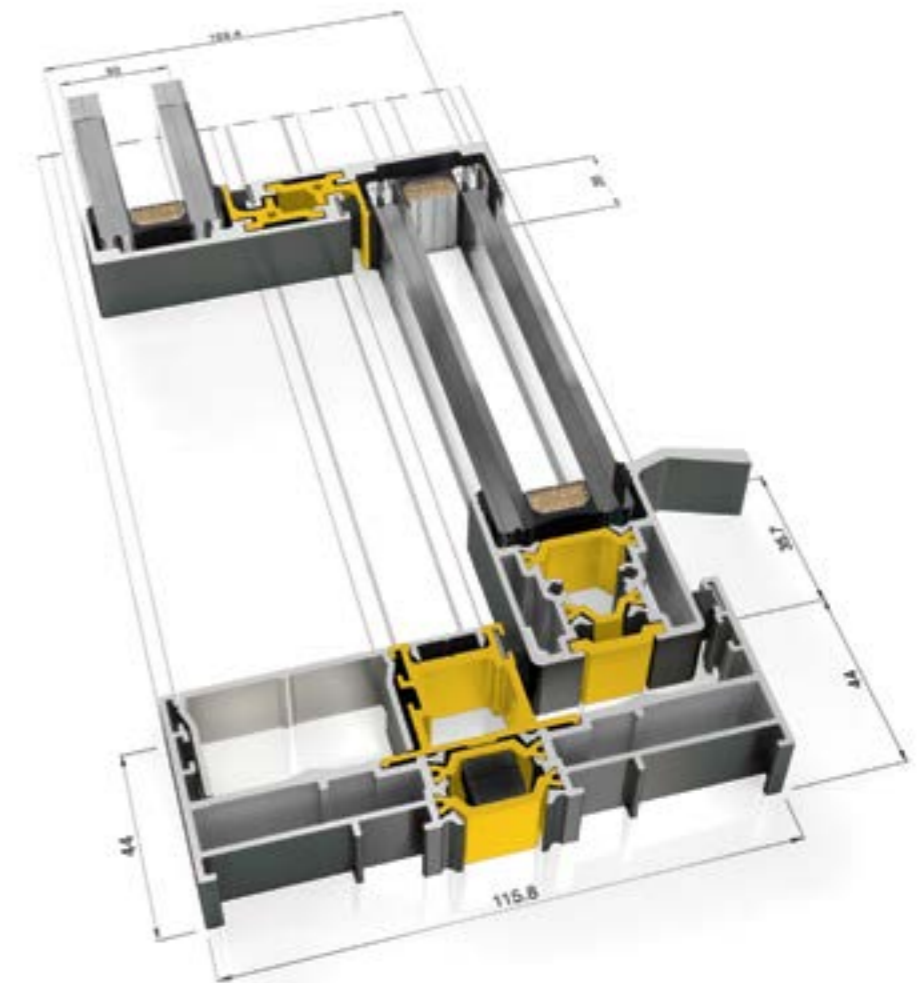

**Size Limits**

Maximum Panel Width	2500 mm
Maximum Panel Height	3000 mm
Maximum Panel Weight	320 kg

**INFINI**GLIDE<sup>3</sup>

THE ULTRA SLIM NEW  
MINIMAL SLIDING DOOR  
WITH A 20MM SIGHTLINE

Every horizon is worth seeing, and now you can enjoy amazing views from the comfort of your home. InfiGlide 3 is the perfect, ultra slim frame to bring your outdoors inside.

- Ultra Slim 20mm Interlock
- Up to 2.5m x 3m Per Panel
- Fully Concealable Frame & Threshold
- 3 Tracks & Pocket Door Option
- Fully Openable With Glass-To-Glass Corners
- Multi-Point Locking

THRESHOLD HEIGHT	44 mm	
GLAZING THICKNESS	26-30 mm	
GLAZING METHOD	Structurally bonded	
MINIMUM SIGHTLINE	20 mm	
FRAME DEPTH	1 RAIL	116 mm
FRAME DEPTH	2 RAIL	116 mm
FRAME DEPTH	3 RAIL	182 mm

PERFORMANCE	
U-VALUE	From 1.3 W/m²K
AIR PERMEABILITY	Class 4
WATER TIGHTNESS	Class 7A
WIND RESISTANCE	Class C5
MAXIMUM ACOUSTIC INSULATION	41 dB Rw
ENHANCED SECURITY	Multi-Point Locking

\*Specifications show what can be achieved with the system but not all products will meet them automatically (depending on size, configuration, e.t.c.). Any specific requirements should be discussed with the technical team before ordering. The specifications on this page are subject to change without warning.