



GT55 TB  
Commercial Door

SECURE  
ROBUST  
HEAVY DUTY



Quantum Windows

Quantum Windows  
11 Causeway Road  
Corby  
NN17 4DU

01536 260300

[quotes@quantumwindows.co.uk](mailto:quotes@quantumwindows.co.uk)



# GT55 TB COMMERCIAL DOOR

An effective choice for shop fronts, entrances and ground floor treatments, the GT55 TB provides exceptional security and performance. Delivering high levels of energy efficiency thanks to its thermally broken profiles, the system has been designed in a ladder frame construction to provide a flexible solution for low-rise glazing applications. This means sealed units of 6mm up to 28mm can be accommodated to improve thermal and acoustic performance.

The system offers PAS 24 rating and is Secured By Design-accredited across a suite of configurations including single and double doors, screening, and side and fan lights. It also features a range of PAS 24 hardware including panic, mechanical and electro-mechanical locking for both single and double doors. Easily integrated with other AluK systems, the GT55 TB includes an integrated range of high traffic, anti-finger trap doors suitable for single storey applications.

## DESIGN FEATURES

- Pocket or bead glazed for ease of site glazing
- 110mm frame depth for varying types of applications
- Slim 55mm profile width
- Fully compatible with other AluK systems
- Mullion drainage options
- PAS 24 and Secured By Design certified
- Robust mechanical connection detail between rail and stile for ultimate strength in high traffic environments
- Can be used to create louvred and panelled doors with a variation of inserts

## OPTIONS

- Wide range of hardware available offering full customisation
- Available in single or dual colour polyester powder coating, texture and anodised finishes
- Ability to accommodate various architectural pull handles from other manufacturers

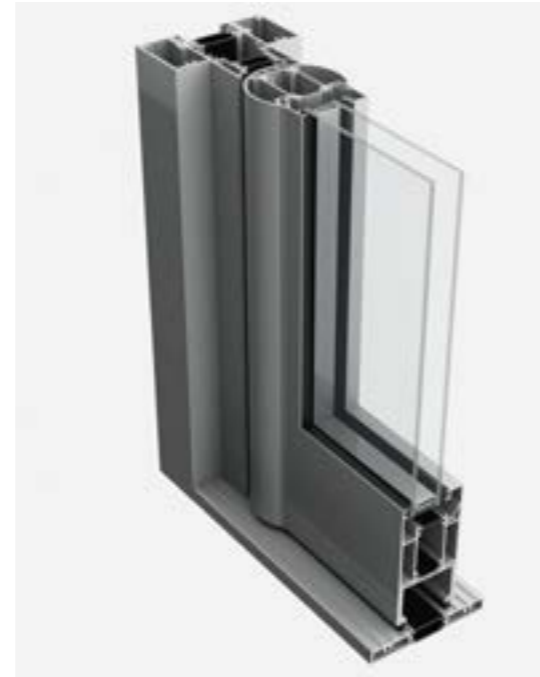

Jamb with Anti-Finger Trap

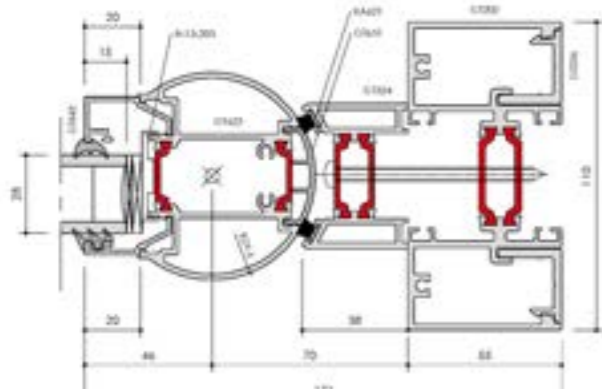

Jamb with Multi-Point Lock

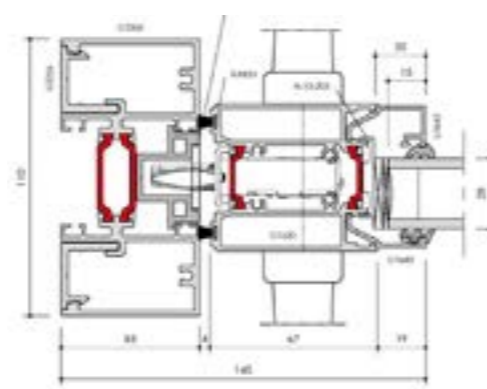

Thermal Profile

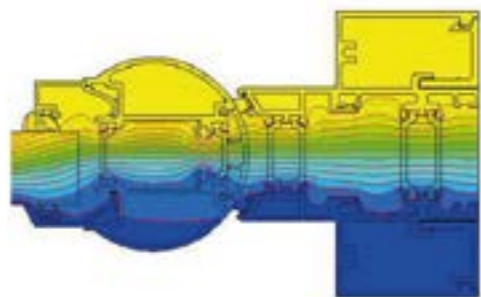

Meeting Stile

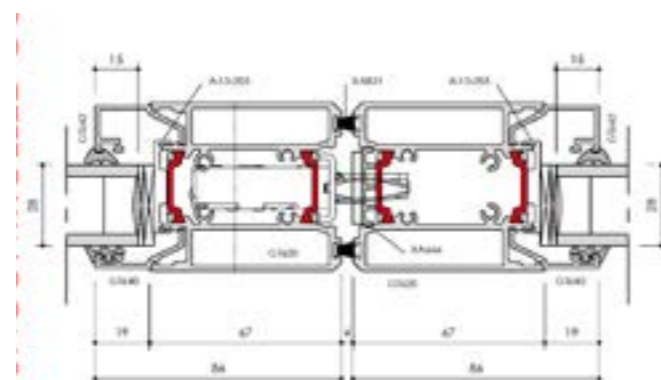

## SPECIFICATIONS

PERFORMANCE & ACCREDITATION	SINGLE	DOUBLE	GT55 TB SCREENING
U-Value Double Glazing (ug: 1.0 W/m²K)	1.9 W/m²K	1.8 W/m²K	1.3 W/m²K
U-Value Triple Glazing (ug: 0.7 W/m²K)	1.7 W/m²K	1.6 W/m²K	1.1 W/m²K
Air Permeability	-	-	Class 4 (600 Pa)
Water Tightness	-	-	Class E1200 (1200 Pa)
Wind Resistance	-	-	Class B4 (1600 Pa)
Durability EN 1191 Category	50,000 Cycles	50,000 Cycles	-
Security	PAS 24 & SBD	PAS 24 & SBD	PAS 24 & SBD
3rd Party Certification Q-Mark	✓	✓	✓
SYSTEM DEPTH			
Units (mm)	110mm	110mm	110mm
SIZE AND WEIGHT LIMITS			
Maximum Door Leaf Size	1250 w x 2400 h	2500 w x 2400 h	-
Maximum Door Weight	110kg	110kg	-
GLAZING THICKNESS			
Single Glazed	-	-	6mm - 12mm
Double Glazed	24mm - 40mm	24mm - 40mm	24mm - 30mm
SYSTEM FEATURES			
Single Colour	✓	✓	✓
Dual Colour	✓	✓	✓
Textured Finish	✓	✓	✓
Anodised Finish	✓	✓	✓
Thermally Broken	✓	✓	✓
Fire Exit Option	✓	✓	✓
Part M Compliant Low Threshold	✓	✓	-
Part M Compliant Closer	✓	✓	✓
Anti-Finger Trap	✓	✓	-
Sightlines	145mm	176mm	55mm
Mid-Rail and Lay Bar	✓	✓	✓
Panel Door	✓	✓	-
Multi-Point Locking	✓	✓	-
Single Point Locking	✓	✓	-
Concealed Hinges	✓	✓	-
Barrel Hinges	✗	✗	-
Electro Mechanical Locking	✓	✓	-
APPLICATIONS			
New Build - Residential	✓	✓	✓
New Build - Commercial	✓	✓	✓
Refurbishment	✓	✓	✓
Heavy Commercial	✓	✓	✓

Screen Cill

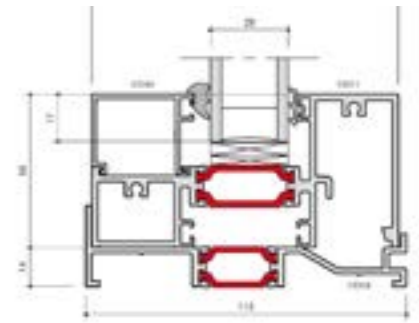

Screen Mullion

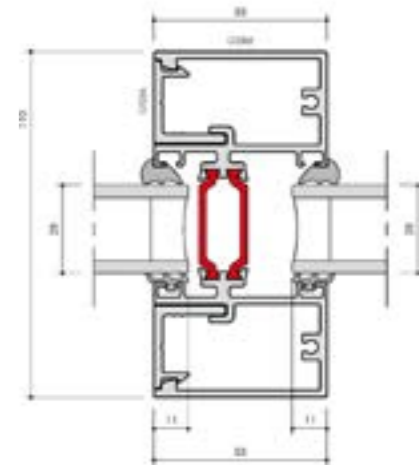

Cill

